

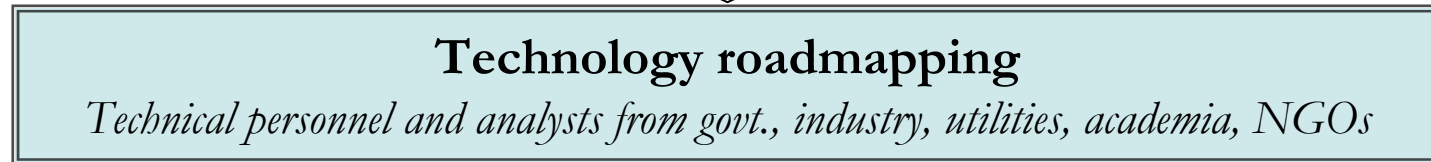

# Technology Roadmapping Process

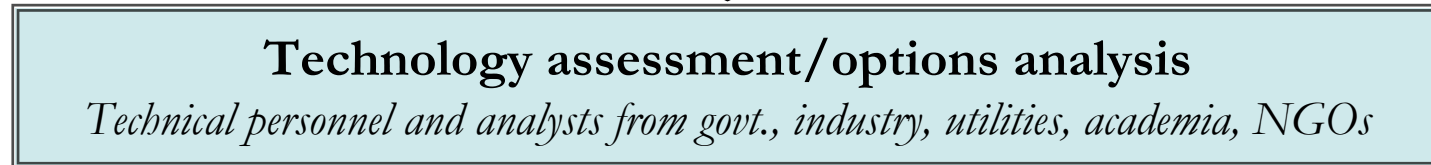

## Technology innovation

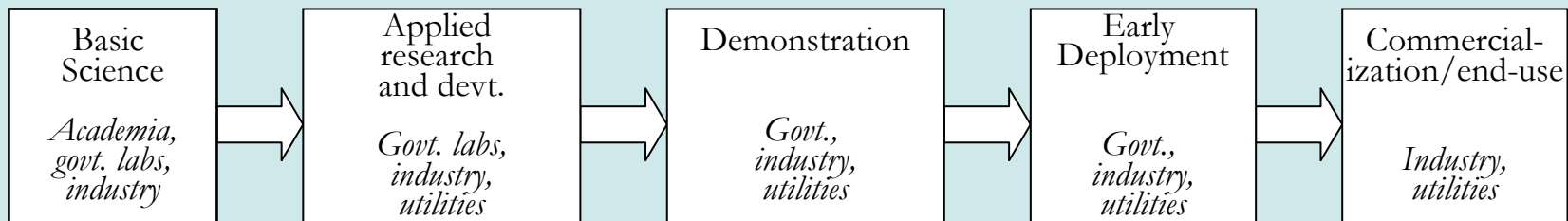

# Innovation Linkages

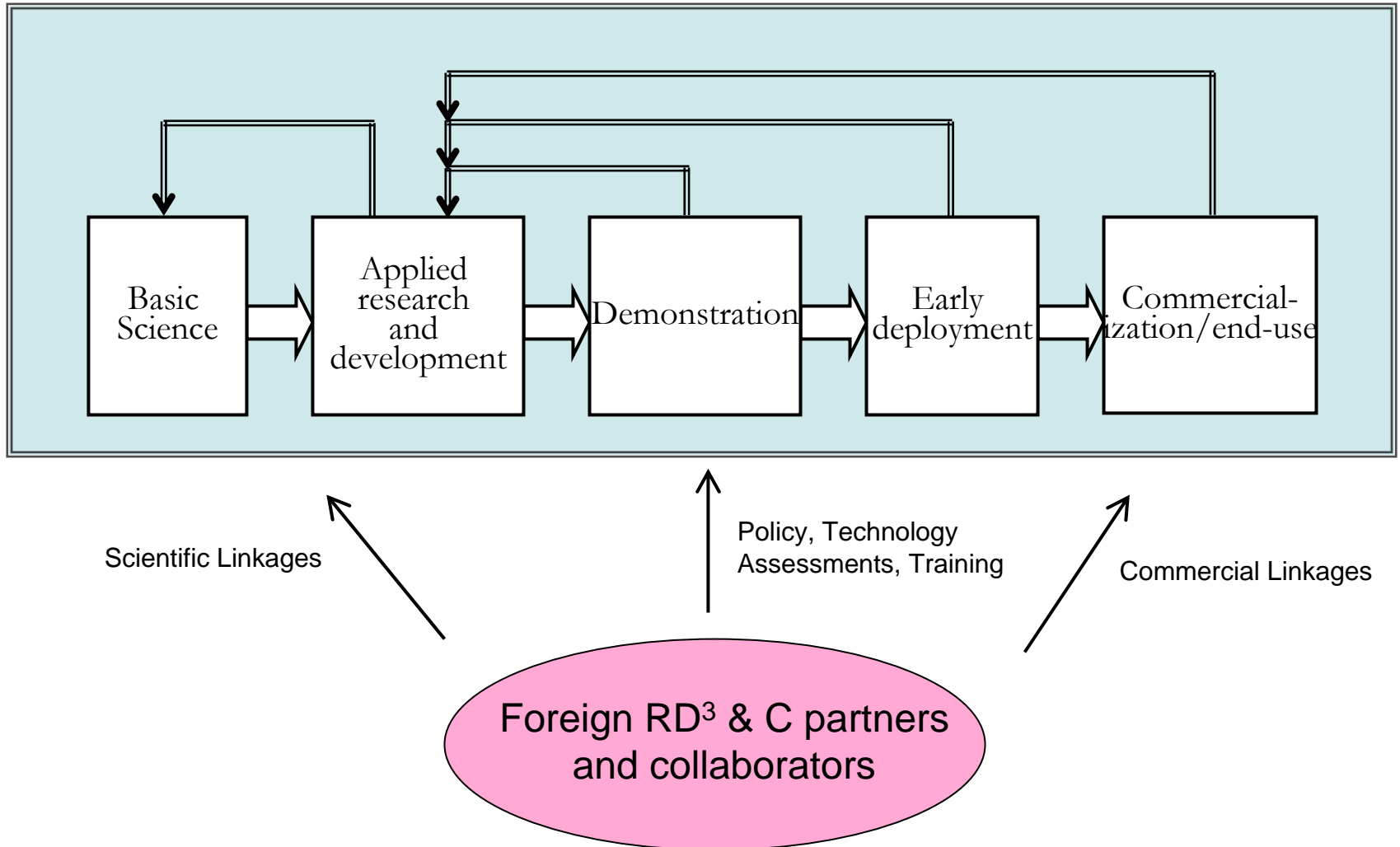

# Selected Bibliography

- Goldemberg, J. (1998), '*Leapfrog energy technologies*', Energy Policy, 26 (10), 729-742.
- Freeman, C. (1992), Economics of Hope. Pinter Publishers, London.
- Lall, S. (1992), '*Technological Capabilities and Industrialization*', World Development, **20**(2), 165-186.
- Lall, S. (1987). Learning to Industrialize: The Acquisition of Technological Capacity by India. Macmillan Press, London.
- Chikkatur, A. P. and A. D. Sagar (2007), '*Cleaner Power in India: Towards a Clean-Coal-Technology Roadmap*', (to be published) BCSIA Working Paper Series, Kennedy School of Government, Harvard University.
- Sagar, A.D. (2002), '*Technology, Innovation, and Energy*' Encyclopedia of Energy.
- Perkins, R. (2003), '*Environmental leapfrogging in developing countries: A critical assessment and reconstruction*' Natural Resources Forum 27(3), 177-188